



Pingo drinking troughs

In order to produce a lot of milk, a cow must also have easy access to water and be able to drink plenty of it. This makes a drinking trough the perfect choice.

The Pingo series was developed by not just taking the cow and farmer's needs into account, but also with its installation in mind. This has resulted in a new generation of drinking troughs.

The cow must be able to drink easily and safely, which requires a generous opening. A protective brace without any sharp edges has been integrated into the trough. Troughs can be supplied in lengths of 1, 2 or 3 metres to suit different group sizes.

It needs to be easy for the farmer to provide water that is as clean as possible. The troughs can be emptied through a discharge outlet of almost 9 centimetres which has the familiar Spinder plug (cannot be pulled out by the animals). The bottom slopes down to the discharge outlet, which means that any dirt is carried away when the trough is emptied.

The float is located under a cover for protection. When necessary, the float cover can be removed quickly and easily; without tools. Easy to clean, check, maintain. To prevent the float from being frozen the Pingo is fitted with a circulating pipe so that the water continues to flow.

The Pingo is very robust and comes fully equipped. Normally supplied for wall mounting but floor mounting is also possible. Connection pipe and couplings (stainless steel, 1" male thread) are included.

To make installation as convenient as possible, the float can be installed in various positions so that it can be connected directly to the water supply. This helps keep installation costs to a minimum.

The benefits of comfort

Pingo 100, 200 en 300.

Comfort for the cow:

- Fully cow-friendly; no sharp edges, surrounded by a protective stainless steel brace.
- Natural supply of water: generous drinking surface.
- Three sizes.

Convenience for the farmer:

- Easy to clean thanks to the sloping bottom and the removable plug.
- Simple to clean because the float can be reached without tools.
- Universal; can be mounted on the wall or on the floor.

Convenient to install (time is money):-

- Direct connection to the water supply because the float can be mounted in various positions.
- Quick connection as all the connection parts and couplings are supplied.
- Easy frost protection thanks to the stainless steel circulation pipe which is also supplied.

Models:

	length ca. cm	capacity ca. litres
Pingo 100	120	50
Pingo 200	220	100
Pingo 300	320	150

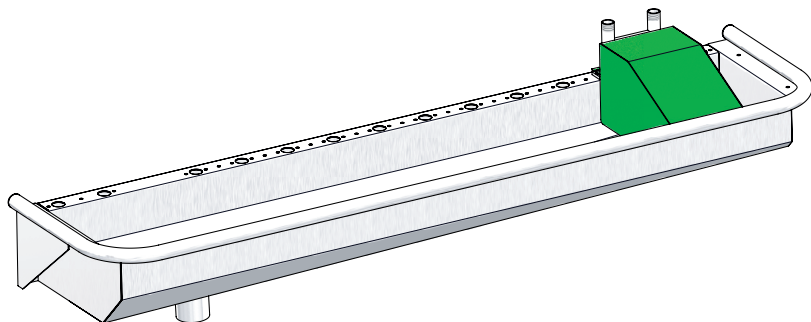

Optional:

- Set of support legs for floor mounting.

Comfortable
water supply!

spinder
DAIRY HOUSING CONCEPTS

Reitsmastrjitte 48
9281 LE Harkema
The Netherlands

☎ 00 31 (0)512 - 369160
E-mail: sales@spinder.nl
www.spinderdhc.com

